

Standard accessories



WIDTH GAUGE

Optional accessories



RL CUP Ø 40
Large plastic cup with rubber ring for alloy rims protection

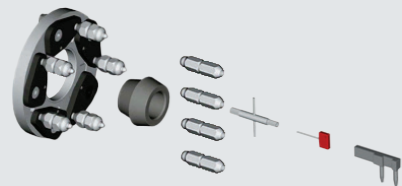

UH20/2 Ø 40
Universal adapter for wheels with 3,4,5,6 holes. Complete with back centering double cone for wheels with/without central holes

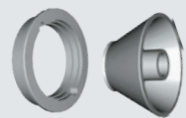

VL/2 CONE + G36 DISC
Kit for light truck wheels (Ø 97÷170 mm centre hole)



MT2 CONE Ø 40
Stepped cone for Porsche - Audi - Opel - Volkswagen - BMW - Smart (Ø56,5 / 57 / 66,5 / 72,5 mm centre hole)

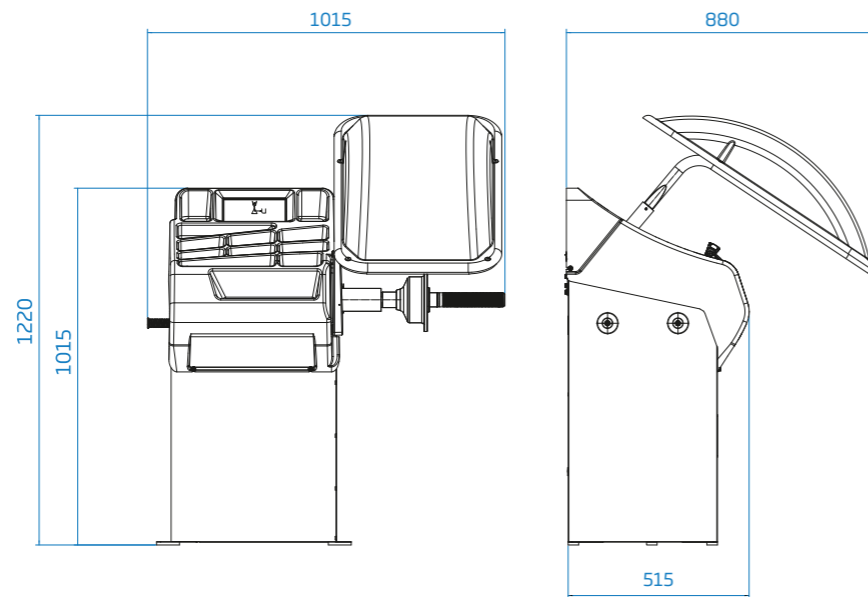

Technical Data

Single phase power supply	230V/1ph/50 hz
	115V/1ph/60 Hz
Max. absorbed power	0,15 kW
Balancing speed	100 rpm
Measurement spin time for 15 kg (33 lb) wheel	4.7 s
Measurement uncertainty	± 0,5 g
Resolution	0,5 g
Average noise	< 70 dB (A)
Rim width setting range	1.5" ÷ 20" / 40 ÷ 510 mm
Rim diameter setting range	10" ÷ 30" / 265 ÷ 765 mm
Min./Max. compressed air pressure	7 ÷ 10 kg/cm2 / ~ 0.7 ÷ 1 MPa
	~ 7 ÷ 10 bar / ~ 105 ÷ 145 psi
Max. wheel weight	< 75 kg
Machine weight	110 kg



Optional set up

34" wheel guard



megaspin 220

COMPACT DIGITAL WHEEL BALANCER



Hofmann Megaplan wheel balancers are a concentrate of functionality and technology. Each model is the result of an in-depth analysis of the real needs of the market and ensures optimal results in terms of quality and efficiency.

megaspin 220

COMPACT DIGITAL
WHEEL BALANCER



**AUTOMATIC
GAUGE**

Automatic gauge

The extended automatic gauge allows detecting automatically the distance and diameter of the wheel up to 30". In addition, with the Auto Select function, the machine automatically recognizes whether the rims are made of steel or alloy.



**VIRTUAL
SONAR**

Virtual Sonar

Virtual Sonar is a software able, in the absence of an actual sonar device, to automatically measure the width of steel rims and, therefore, to calculate the position of the second correction plane. Virtual Sonar reduces balancing time by avoiding operator errors caused by manual data entries and guarantees, at the same time, a balancing efficiency.



**DIGITAL
Display**

Digital display

The digital display is simple and durable and allows intuitive use of all machine functions. The software of the M220 has been developed to provide several programs for the tyre professional: SPLIT, OPT, ALU.

Manual locking

M220 is equipped with an easy manual locking system thanks to the quick locknut.



**MANUAL
LOCKING**